

BUSCH MACHINERY

MS-100



FRONT AND BACK LABELING SYSTEM WITH WRAPPING

Product diameter from 15mm to 150mm¹
Speed up to 120 products per minute
Built in stainless steel



32 product memories
Numeric keypad with LCD display

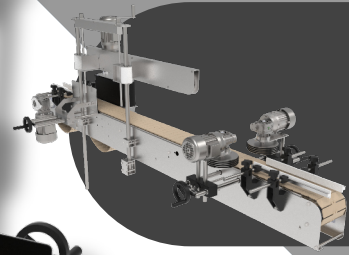

Variable speed with automatic synchronization
Adjustable side guides
With band or three roller wrapping for cylindrical product labeling

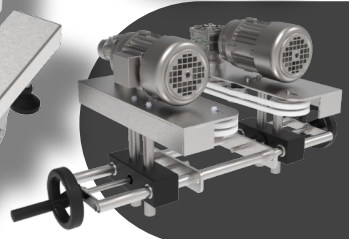

The chain aligner system guides the product, ensuring the correct position of the containers before applying the label

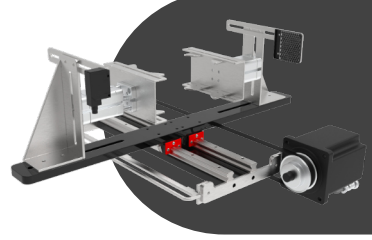

The servo pneumatic aligner system allows to orientate packages with complex shapes



Busch Machinery, Inc.
727 E. 20th St.
Tucson, AZ 85719
Phone: 800-840-9573 (USA Only)
Fax: 800-840-6270 (USA Only)
Phone 520-777-3360
Fax: 520-777-3369
E-mail: sales.inquiries@busch-machinery.com

¹The product must be able to keep itself stable. For unstable products consult our other machines

BUSCH MACHINERY

MS-100

FRONT AND BACK LABELING
SYSTEM WITH WRAPPING

DIMENSIONS

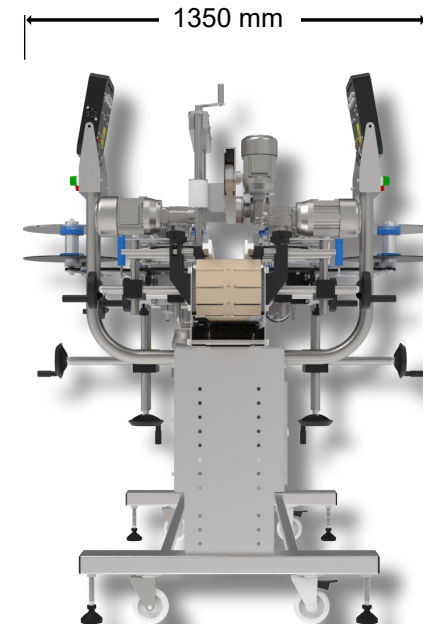
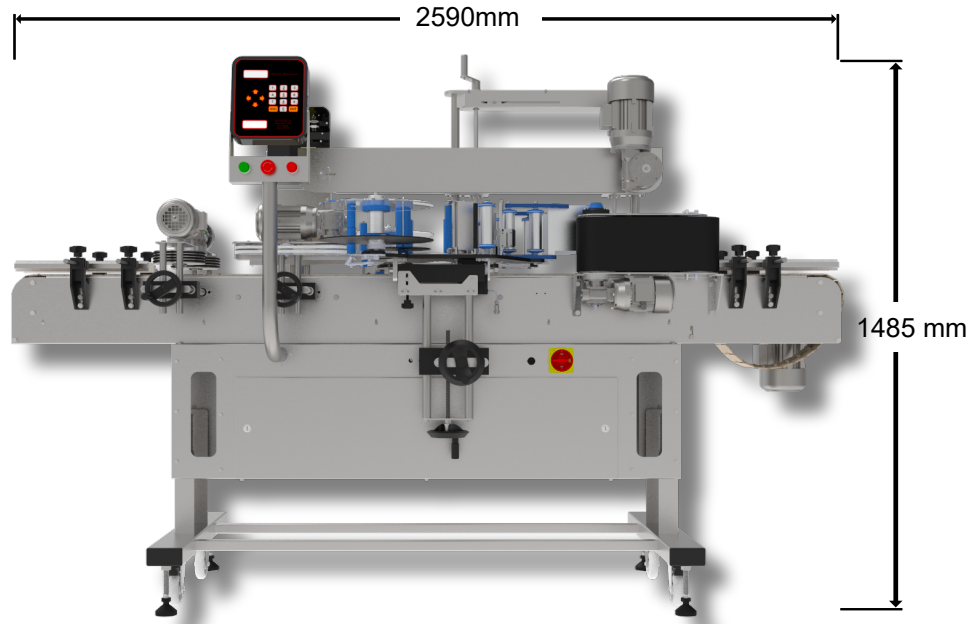

Left Version

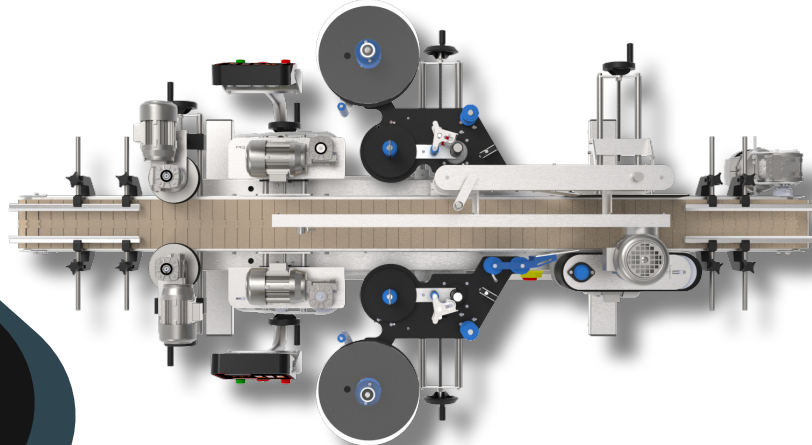

Right Version

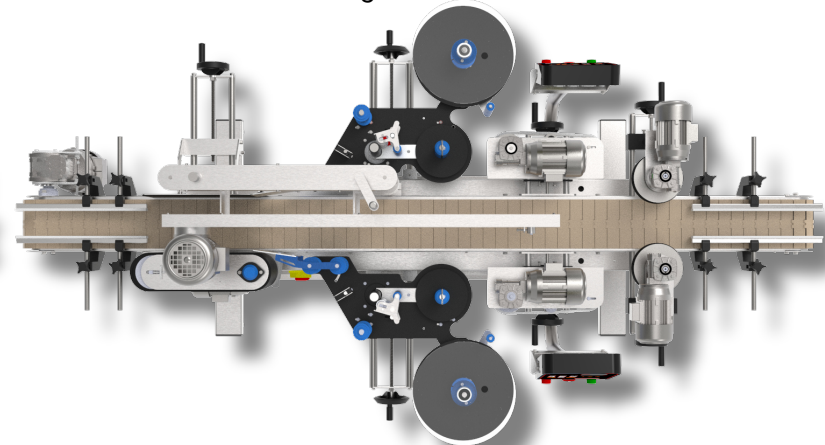

Busch Machinery, Inc.
727 E. 20th St.
Tucson, AZ 85719
Phone: 800-840-9573 (USA Only)
Fax: 800-840-6270 (USA Only)
Phone 520-777-3360
Fax: 520-777-3369
E-mail: sales.inquiries@busch-machinery.com

MS-100

FRONT AND BACK LABELING
SYSTEM WITH WRAPPING

SPECS

Compatible heads	K50, K200, KFLEX
Compatible aligners	Handrail (without alignment) Chain aligner Servo pneumatic aligner
Labeling capacity	Up to 120 labels / min
Labeling speed	Up to 30 m / min. The product can be retained while the label is dispensed depending on the type of application
Label width	Up to 115 or 170 mm depending on the labeling head
Paper roll inner diameter	76 mm
Paper roll outer diameter	Up to 300 mm
Product diameter	152.4 mm (6 in) standard. Possibility of larger diameter on request
Power supply	2 kVA 220V-240V, 50Hz* 110V-120V, 60Hz*
Weight (kg)	300
Dimensions (mm)	2590 x 1350 x 1485

* The equipment is only compatible with one type of electrical supply. You must select the appropriate power supply when placing your order.



Busch Machinery, Inc.

727 E. 20th St.

Tucson, AZ 85719

Phone: 800-840-9573 (USA Only)

Fax: 800-840-6270 (USA Only)

Phone 520-777-3360

Fax: 520-777-3369

E-mail: sales.inquiries@busch-machinery.com